



Budapest University of Technology and Economics
Department of Building Machines, Materials Handling Machines and Manufacturing Logistics
and Department of Construction Technology and Management

Construction Equipment Earthwork & Soil Compaction

Edited by: József Károly Ph.D. student
Revised and translated by: Dr. Zoltán A.Vattai

Budapest, 2009-2010

EARTHWORKS - HEAVY EQUIPMENT

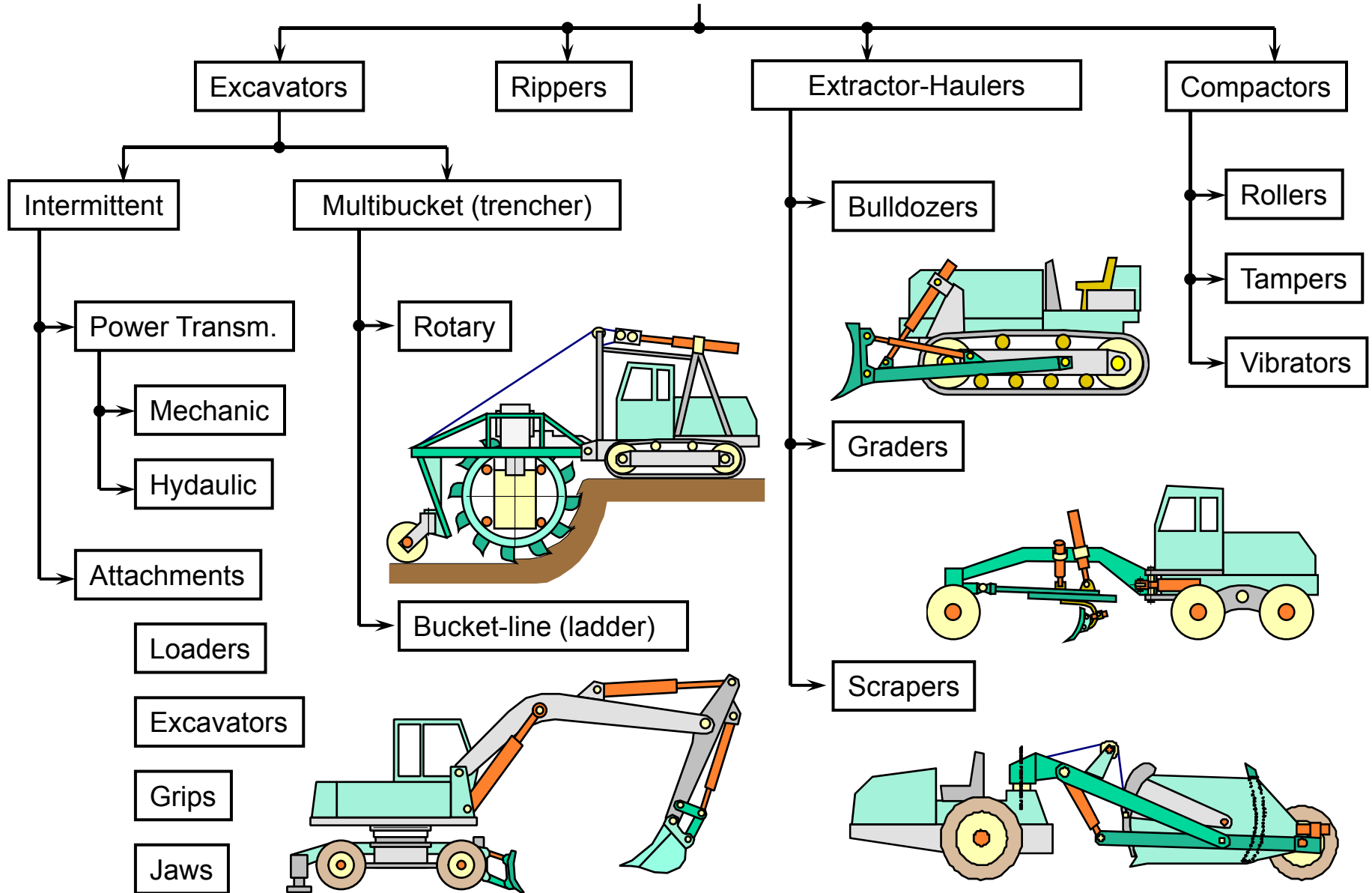

Cable-operated excavators

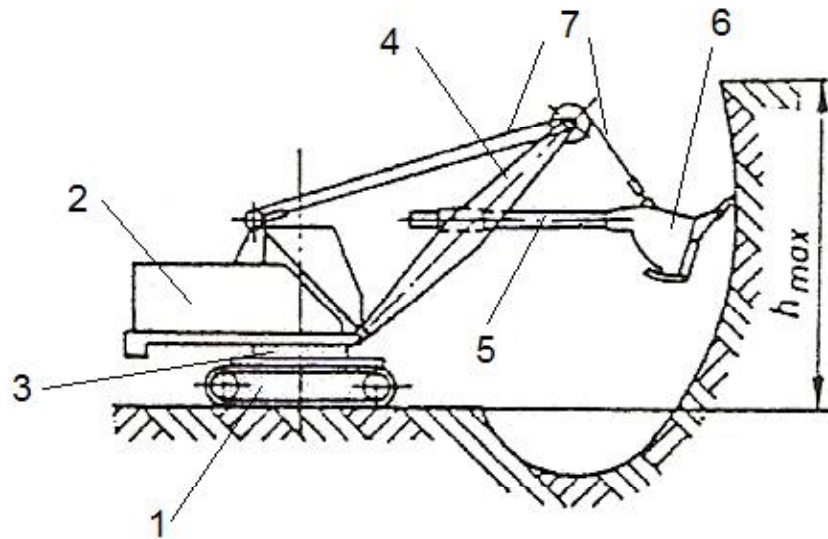

Front shovel

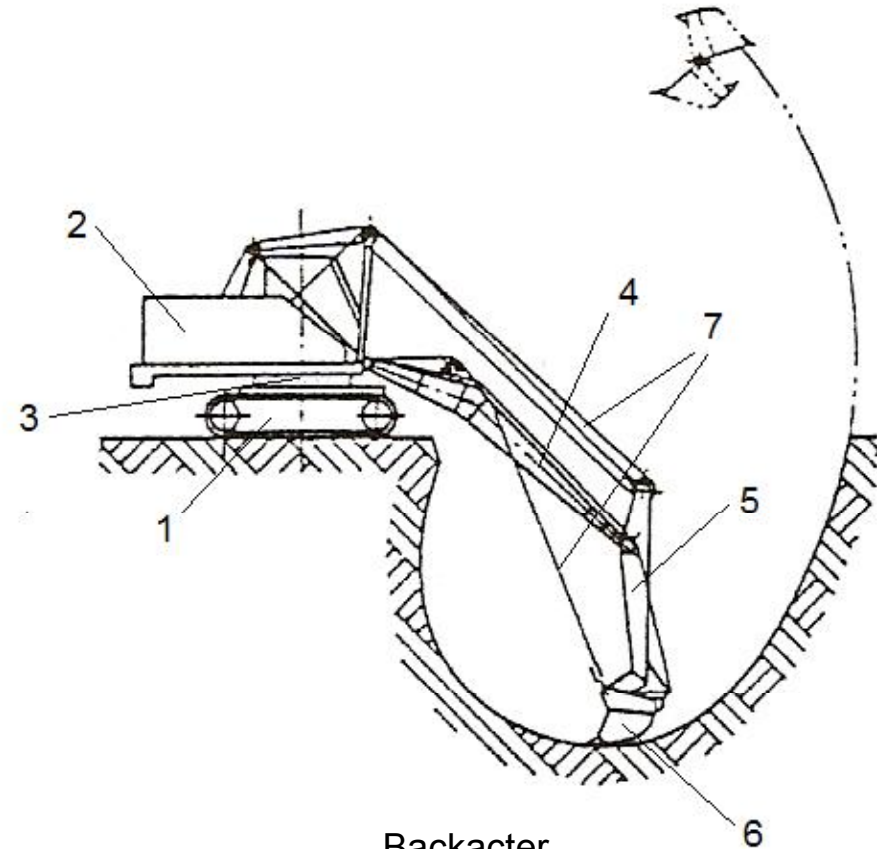

Backacter

1. bogie undercarriage
2. slewing upper machinery (drive, operator's canopy, counter-weight)
3. turn mechanism
4. boom
5. arm
6. bucket
7. cable-lines

Features:

- complicated driving system
- many moving elements → manifold potential failures
- low working performance
- extensive maintenance requirements

Cable-operated excavators

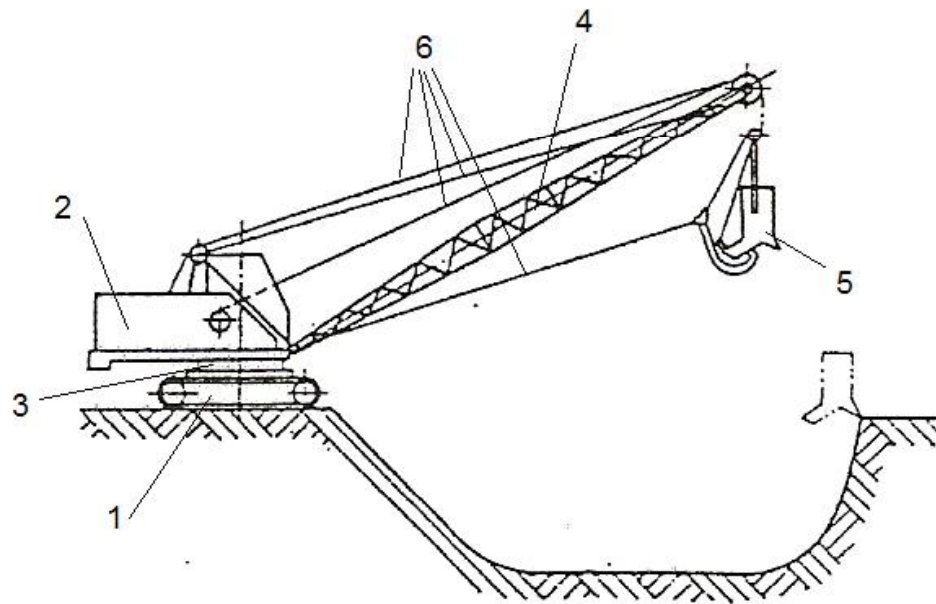

Dragline

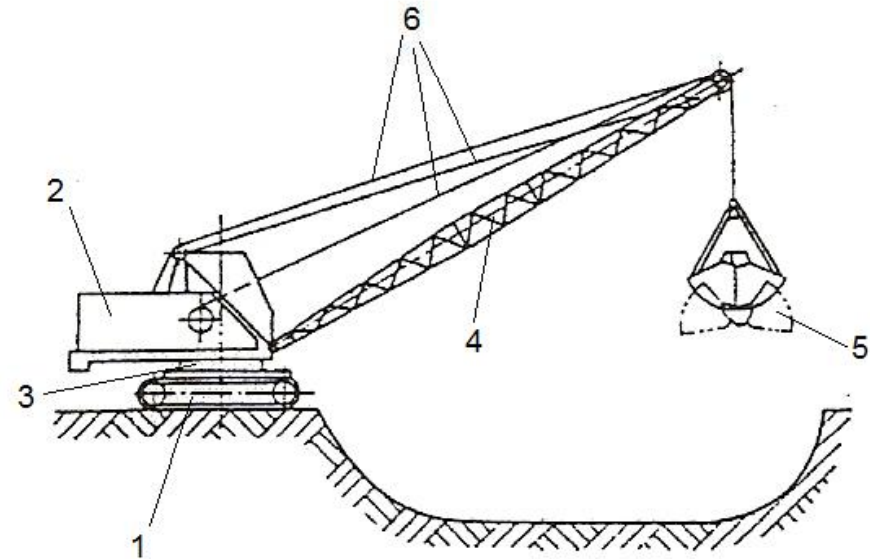

Clamshell

1. bogie undercarriage
2. slewing upper machinery (drive, operator's canopy, counter-weight)
3. turn mechanism
4. boom
5. bucket
6. cable-lines

Features:

- complicated driving system
- many moving elements → manifold potential failures
- low working performance
- extensive maintenance requirements

Cable-operated excavators



- Intermittent (cyclic) operation
- Attachments:
shovel, hook, dragline,
clamshell, boring equipment

Hydraulic excavators (slewing excavators)

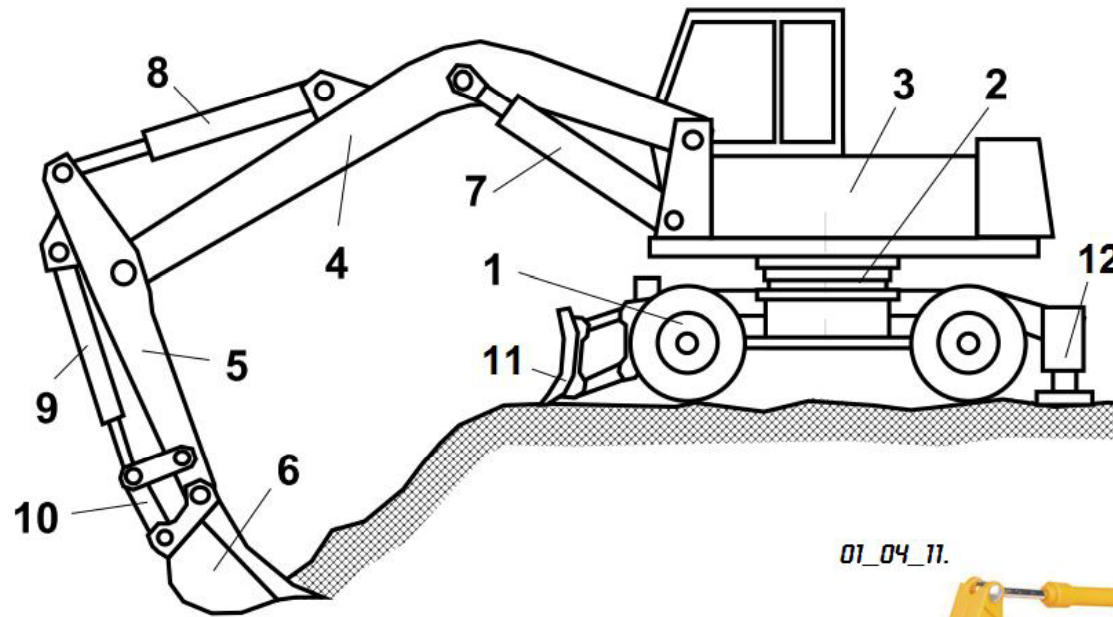

1. wheel-bogie
2. turn mechanism
3. slewing upper machinery
4. boom
5. arm
6. backacter
7. boom cylinders
8. arm cylinder
9. bucket cylinder
10. bucket moving rods
11. auxiliary attachment
12. outrigger

01_04_11.

Wheel-mounted backacter slewing excavator



Hydraulic excavators (slewing excavators)

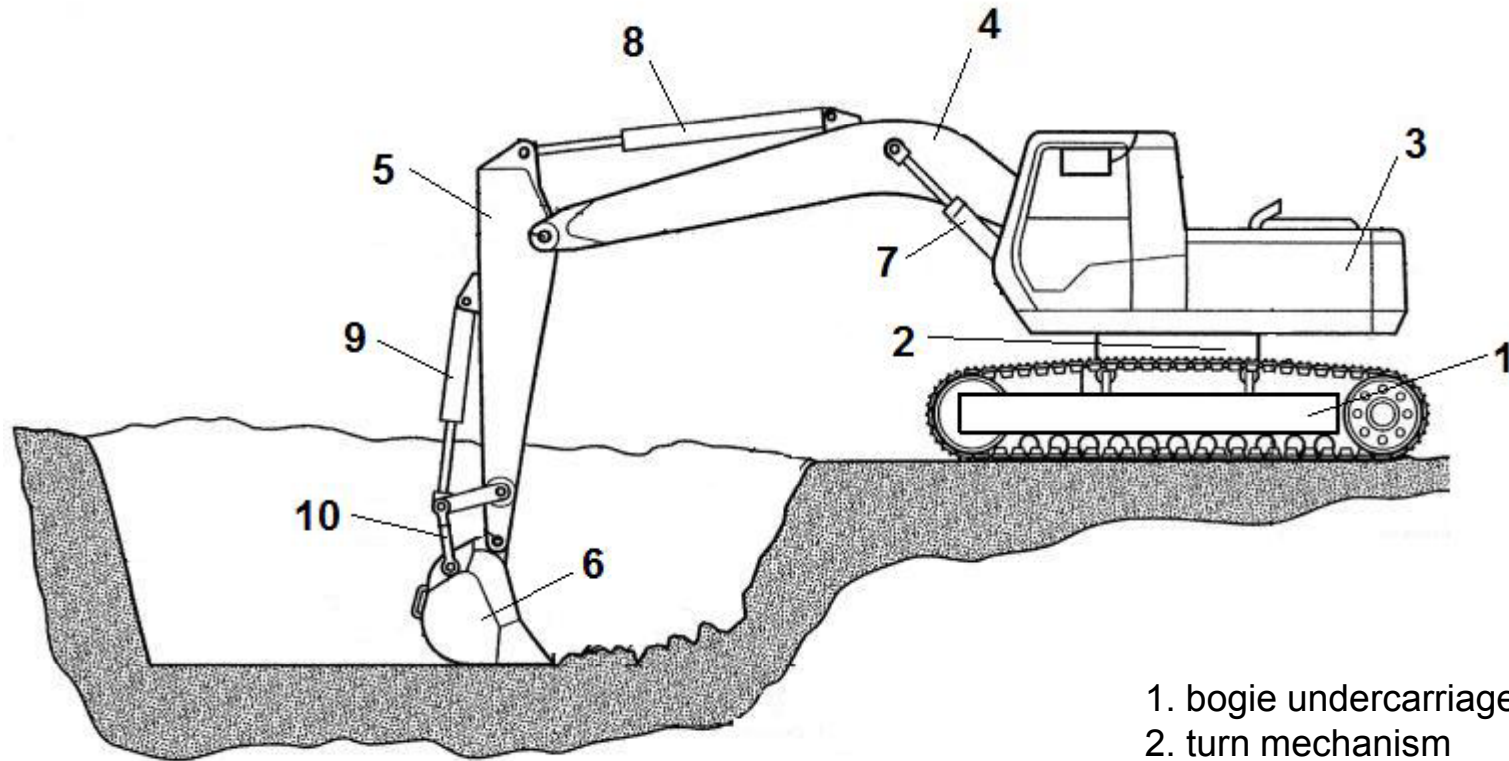

Track-mounted backacter slewing excavator

1. bogie undercarriage
2. turn mechanism
3. slewing upper machinery
4. boom
5. arm
6. backacter
7. boom cylinders
8. arm cylinder
9. bucket cylinder
10. Bucket moving rods

Hydraulic excavators (slewing excavators)

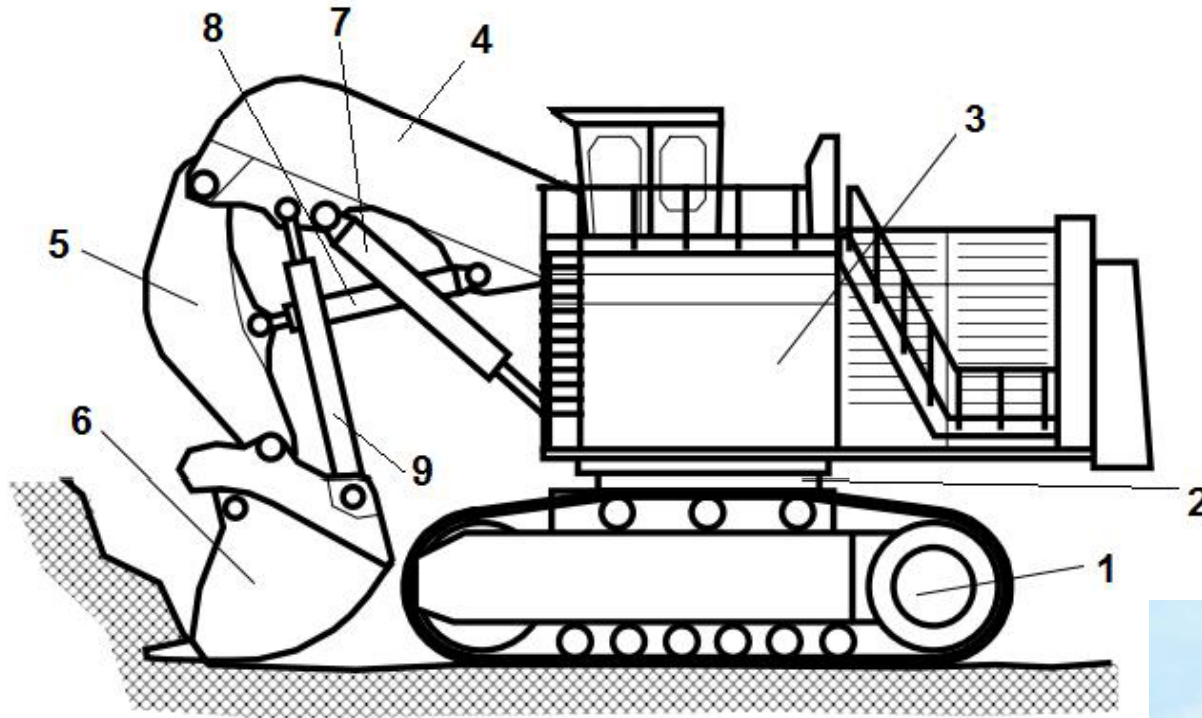

1. bogie undercarriage
2. turn mechanism
3. slewing upper machinery
4. boom
5. arm
6. front shovel
7. boom cylinders
8. arm cylinder
9. shovel moving cylinders

Track-mounted front shovel slewing excavator



Hydraulic excavators (slewing excavators)

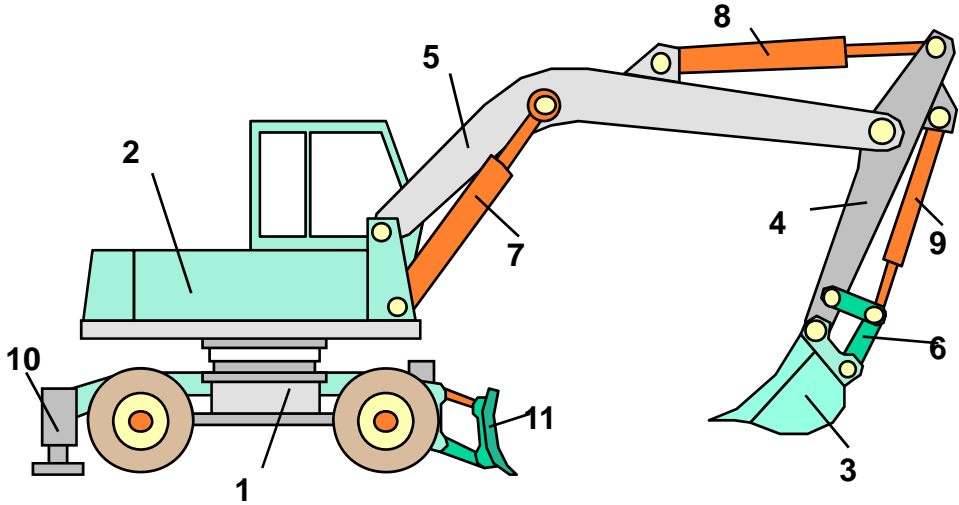

Backacter, wheel-mounted

1. frame (carriage)
2. slewing upper machinery (engine, operator's canopy, counter-weight)
3. hoe (showel or bucket)
4. arm
5. boom (monoblock or articulated)
6. hoe rods
7. boom lifting cylinder
8. arm moving cylinder
9. hoe moving cylinder
10. outrigger (strut, jack)
11. auxiliary attachment (blade)



Front shovel, track-mounted



Excavator (in action)

Attachments



Clamshell bucket (for granular material)



Screening adapter (for recycled material)



Breakers, Jaws
(for concrete, reinforced concrete and steel)

Others: loader bucket; drill; trunk-grip; cutter; trencher; fingered grips (for fibers or bars); crusher; vibro-plate; etc.

Attachments



Sheet-wall piling equipment



Boring (auger) equipment

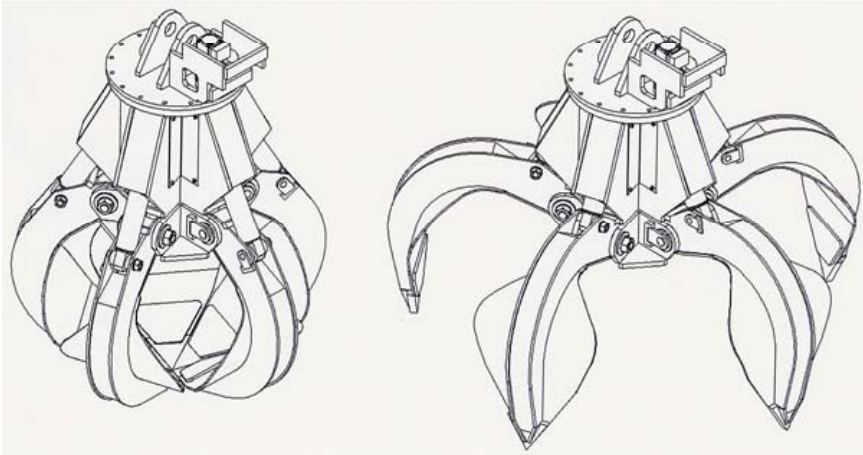

Fingered grip



Crusher adapter

Hydraulic excavator attachments



Backacter bucket



Clamshell

Earthwork attachments



Auger



Ripper

Others: loading attachment; surface vibrator; roller compactor; bucket-lined or rotary trencher; profile buckets; sheet-wall driver; etc.

Hydraulic excavator attachments

Earthwork attachmentst

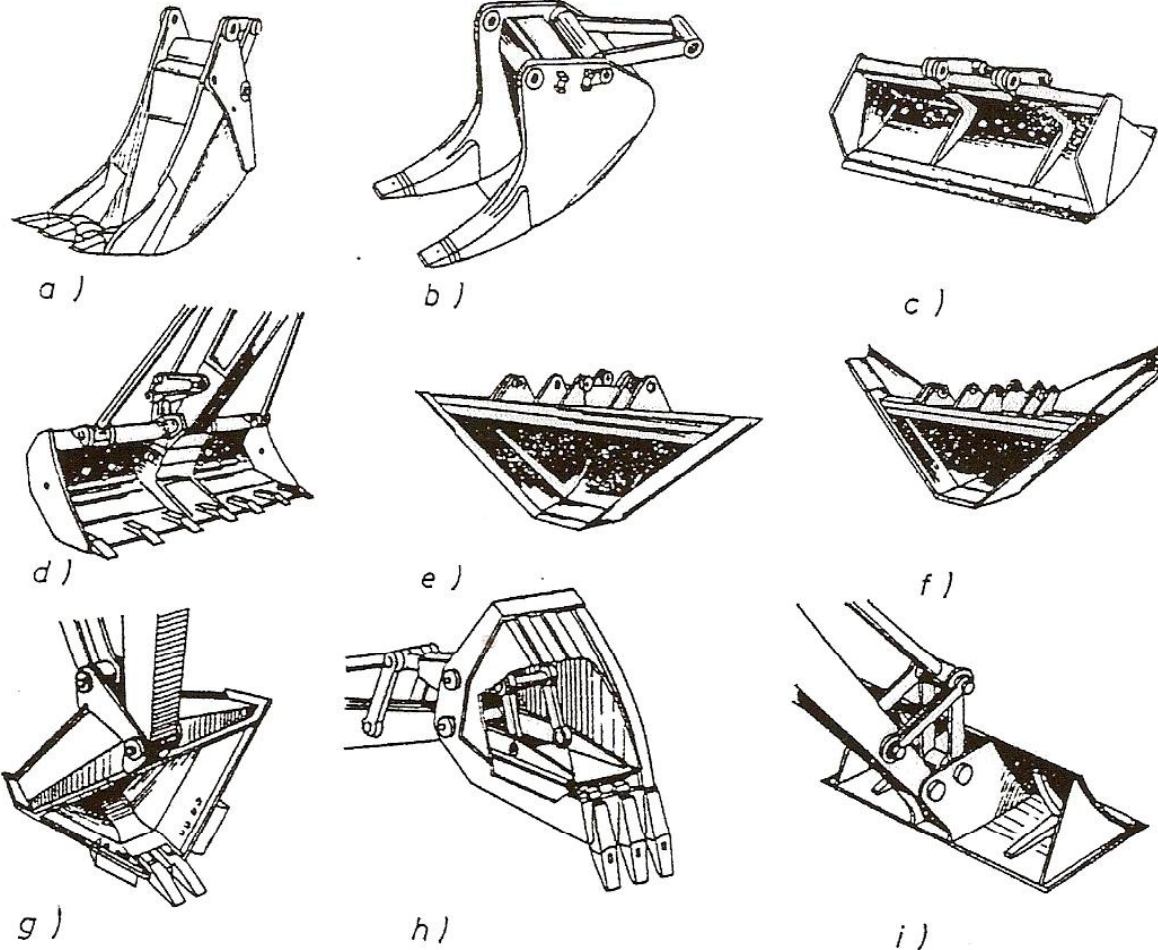

Special bucket-typed attachments

a. drainer; b. ripper; c. canal maintainer; d. ripper-cleaner; e. profile bucket; f. extended cutter; g. ripper-profiler; h. ejector; i. tamper

Hydraulic excavator attachments



Screen drum



Bucket-wheel

Demolisher and Recycler attachments

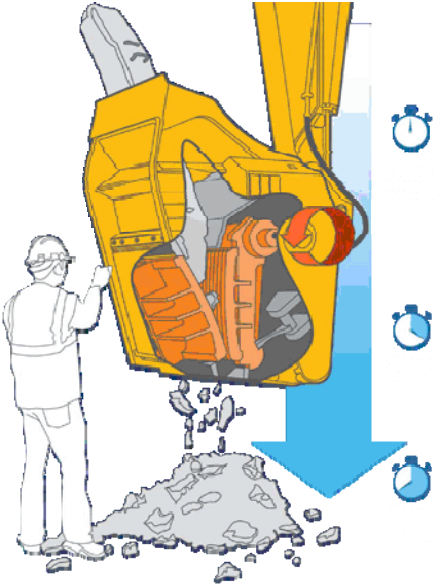

Crusher (mill)



Breaker



Snapper (cutter/jaw)

Hydraulic excavator attachments

Grabs, grips and loaders

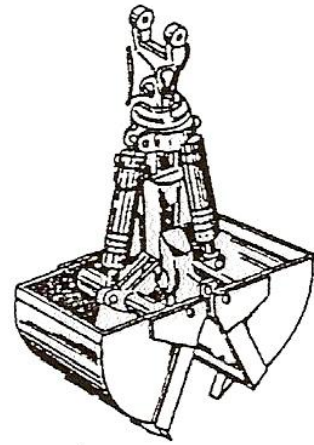

a)

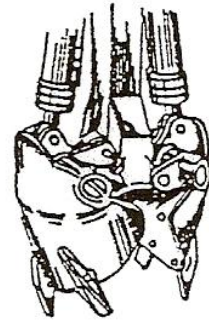

b)

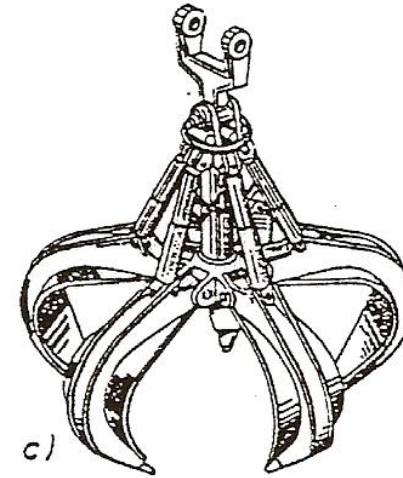

c)

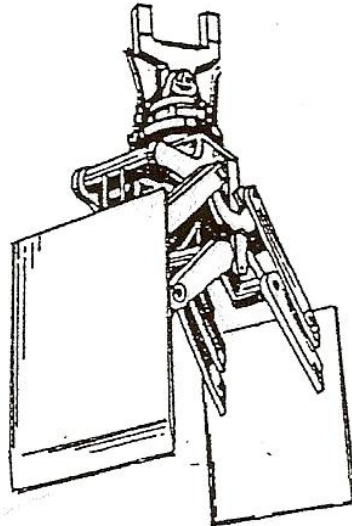

d)

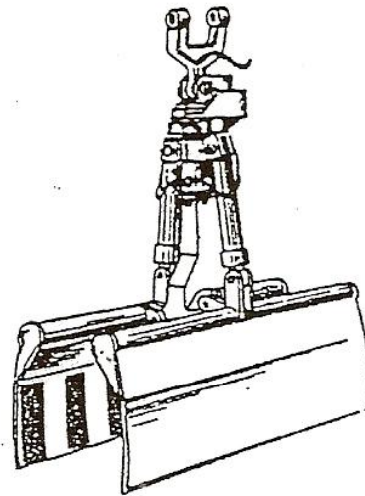

e)

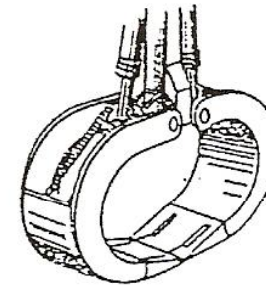

f)

Grabbing and loading attachments

a. clamshell; b. boring; c. fingered; d. bale grip; e. barrel/pipe grip; f. logger

Estimating performance (output) of intermittent excavators

Technical output:

Theoretical technical output (Q_t) assuming ideal circumstances
(soft soil, less than 90° slewing angle, skilled operator, etc.)

$$Q_t = \frac{3600 \cdot q}{t_c} \quad m^3 / h$$

Where

- q = volume (capacity) of bucket [m^3]
- $t_c = t_e + t_{sl1} + t_d + t_{sl2}$ cycle-time (single period) [s]
- t_e = extraction (charging/excavating/loading) time [s]
- t_{sl1} = (lifting and) slewing time (from) [s]
- t_d = discharging (unloading) time [s]
- t_{sl2} = slewing (and lowering) time (to) [s]

Estimating performance (output) of intermittent excavators

Adjusted technical output:

Corrected (adjusted) technical output (Q_a) considering construction of the excavator and behaviour of the soil

$$Q_a = Q_t \cdot \frac{k_f}{k_l} \quad m^3 / h$$

Where

- k_f = bucket fill factor (0,6 – 0,89)
- k_l = soil loosening factor (1,1 – 1,65)

Bucket fill factor is the ratio of volume of soil in the bucket and of technical volume (capacity) of the bucket.

Soil loosening factor is the ratio of volume of excavated loose soil in the bucket and that of compacted (natural) soil before extraction (excavation).

Estimating performance (output) of intermittent excavators

Effective (estimated) output:

Corrected adjusted output (Q_e) considering expected (experienced) time-efficiency of application (operation/site management)

$$Q_e = Q_a \cdot k_t \quad m^3 / h$$

Where

• k_t = time efficiency factor (0,45 – 0,83)

Time efficiency factor is the estimated ratio of effective (factual) and of „calendar” (scheduled) operation time of the equipment on site. It depends on lot of factors and circumstances such as: maintenance demand, skill of operator, idle (waiting) times, manoeuvre (relocating) times, etc.. Experienced values for hydraulic excavators are between 0,45 and 0,83.

Backhoe excavators

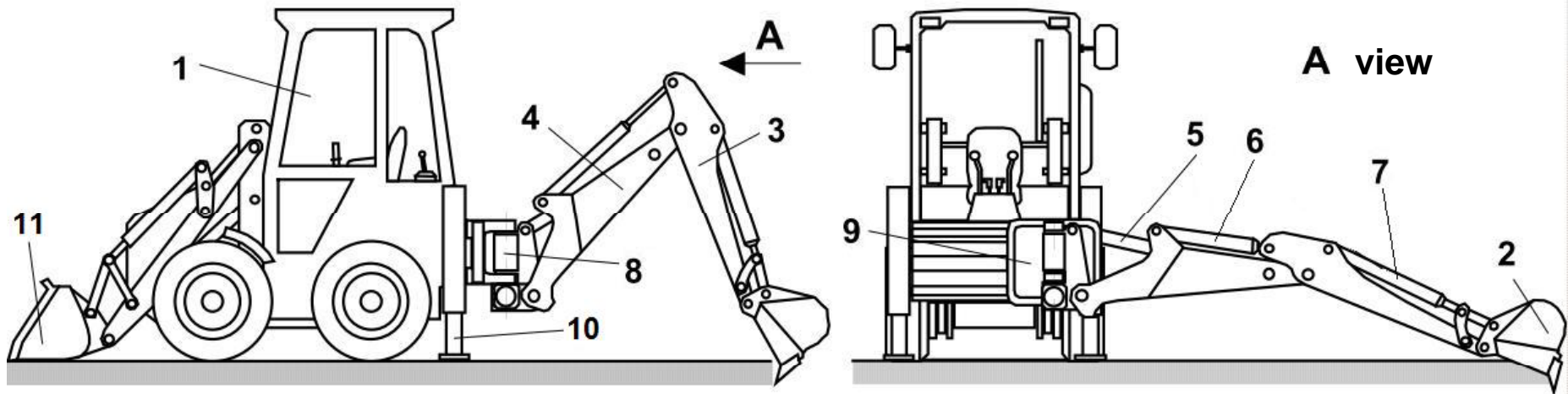

- 1. wheel tractor
- 2. backacter
- 3. arm
- 4. slewing boom
- 5. boom cylinder
- 6. arm cylinder
- 7. bucket cylinder
- 8. slewing mechanism
- 9. suspension (base) plate
- 10. outrigger
- 11. front attachment (loader)



Backhoe excavators

Features:

- ⇒ multifunctional (universal excavator)
- ⇒ base (frame): wheel or track mounted
- ⇒ attachment slewing ability: $\pm 90^\circ$
- ⇒ auxiliary attachment: front bucket or blade

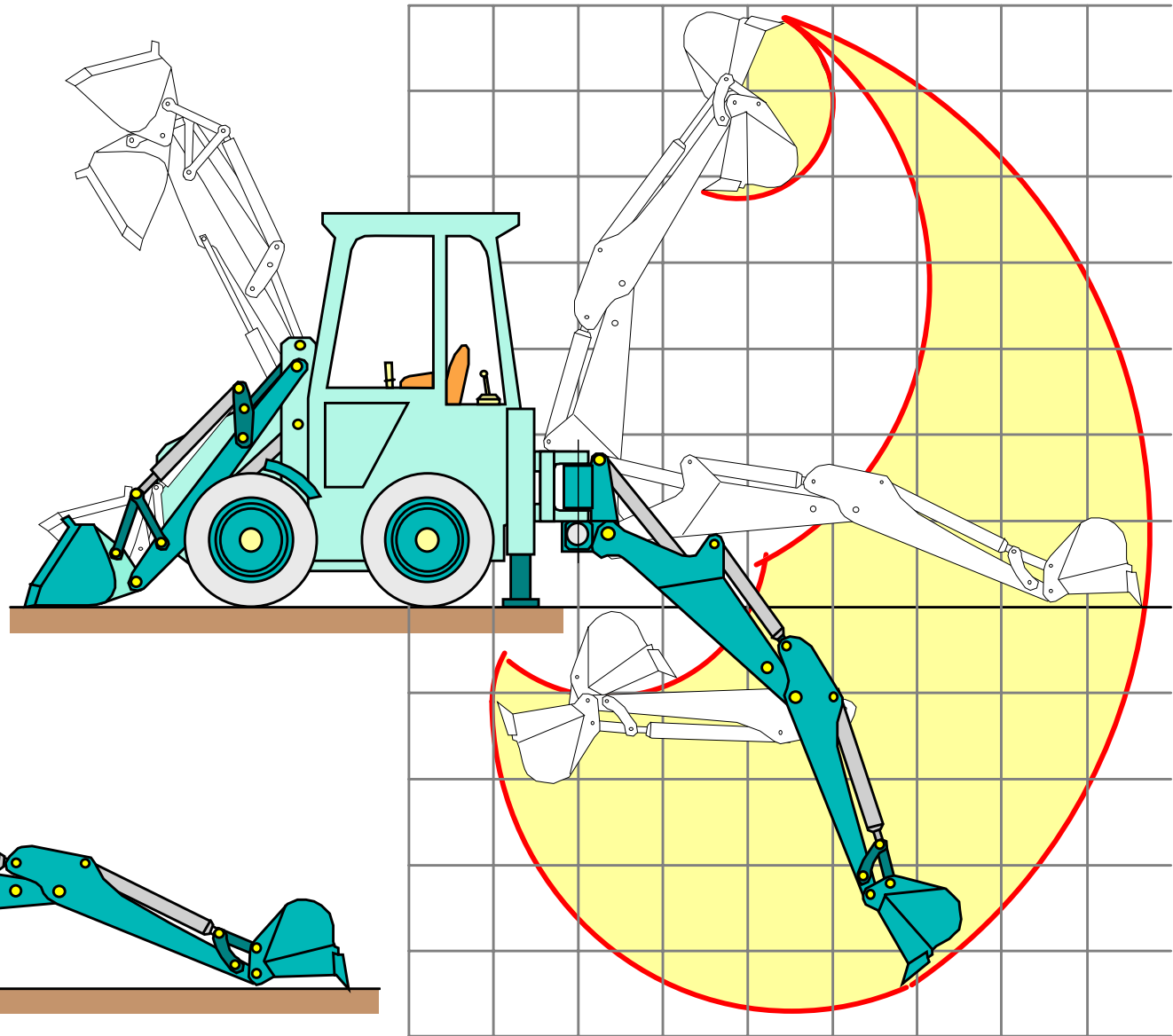
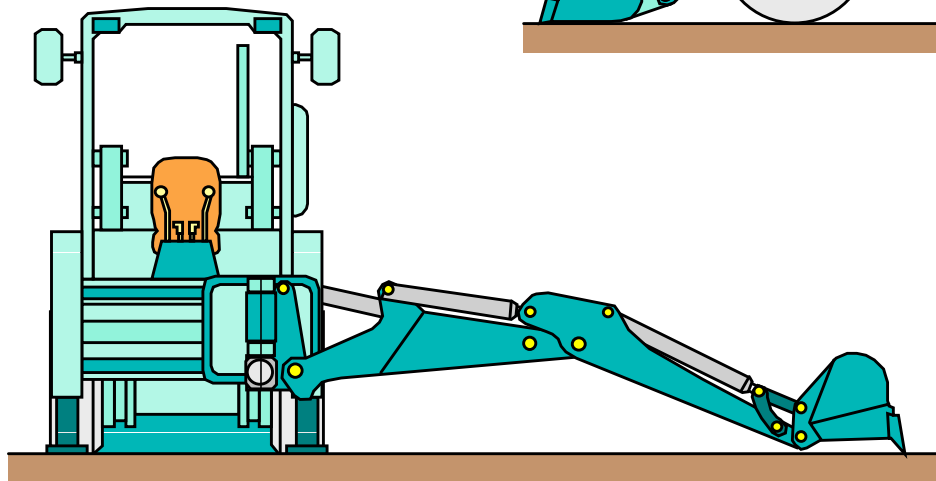

Backhoe's working range (trajectory)

Backhoe excavators



Features:

- Multifunctional front showel
- Draw beam (telescopic arm)
- Transversely slidable boom



A. with rigid frame

Bulldozers (dozers)

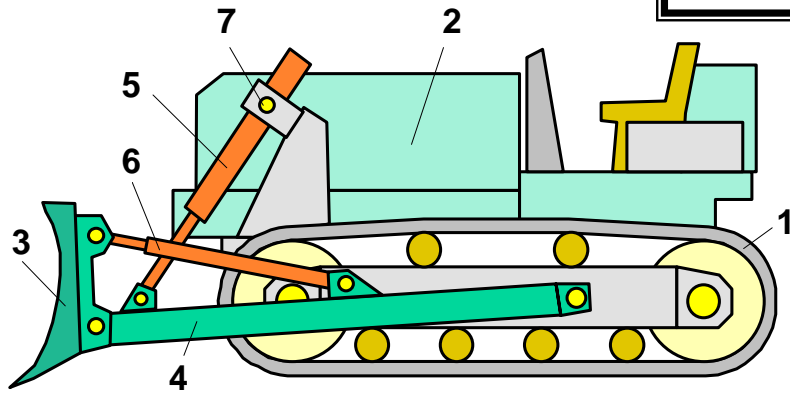

Adjustability of blade:

- ⇒ Cutting depth
 - ⇒ Cutting angle (tilt, adjusted to soil type)
 - ⇒ Slope angle (α)
 - ⇒ Heading angle (β)
- } Ball-jointed main frame only

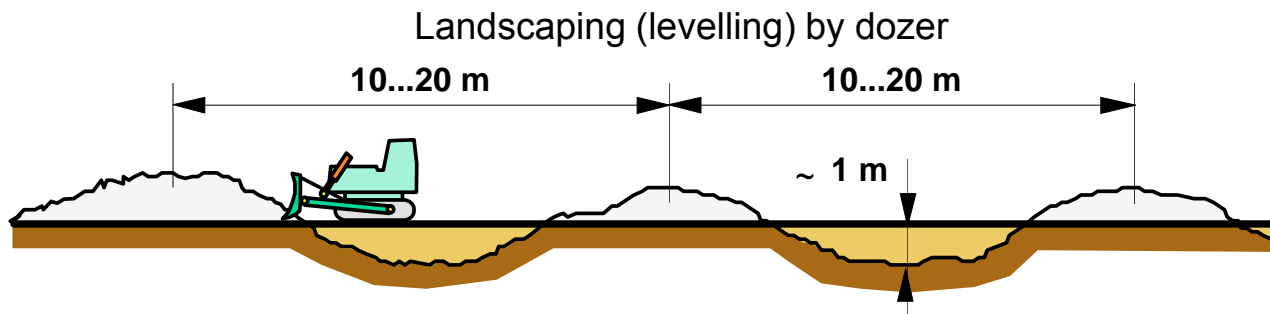

1. track (caterpillar)
2. engine
3. blade
4. main frame
5. lifting cylinder
6. tilting cylinder
7. bolt
8. ball-joint
9. swivel cylinders

B. with ball-jointed frame

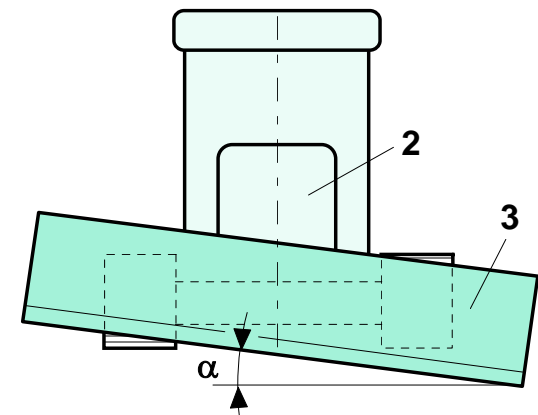
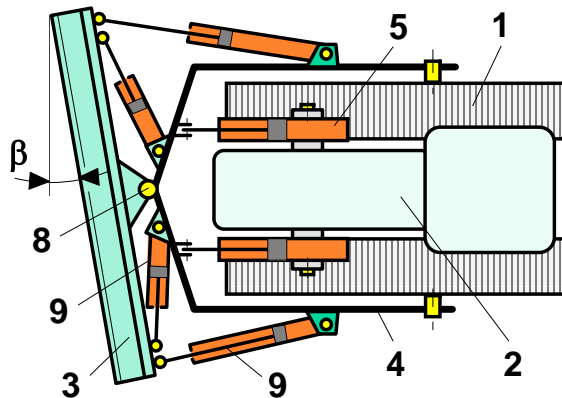

Bulldozers (dozers)

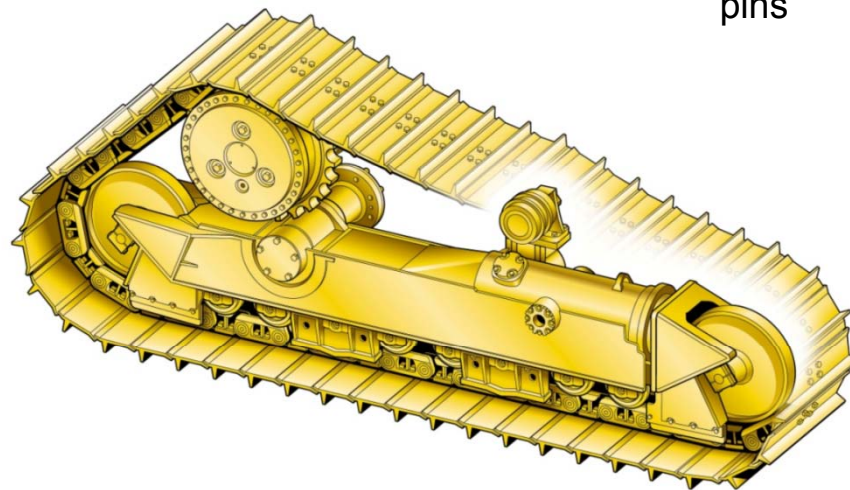
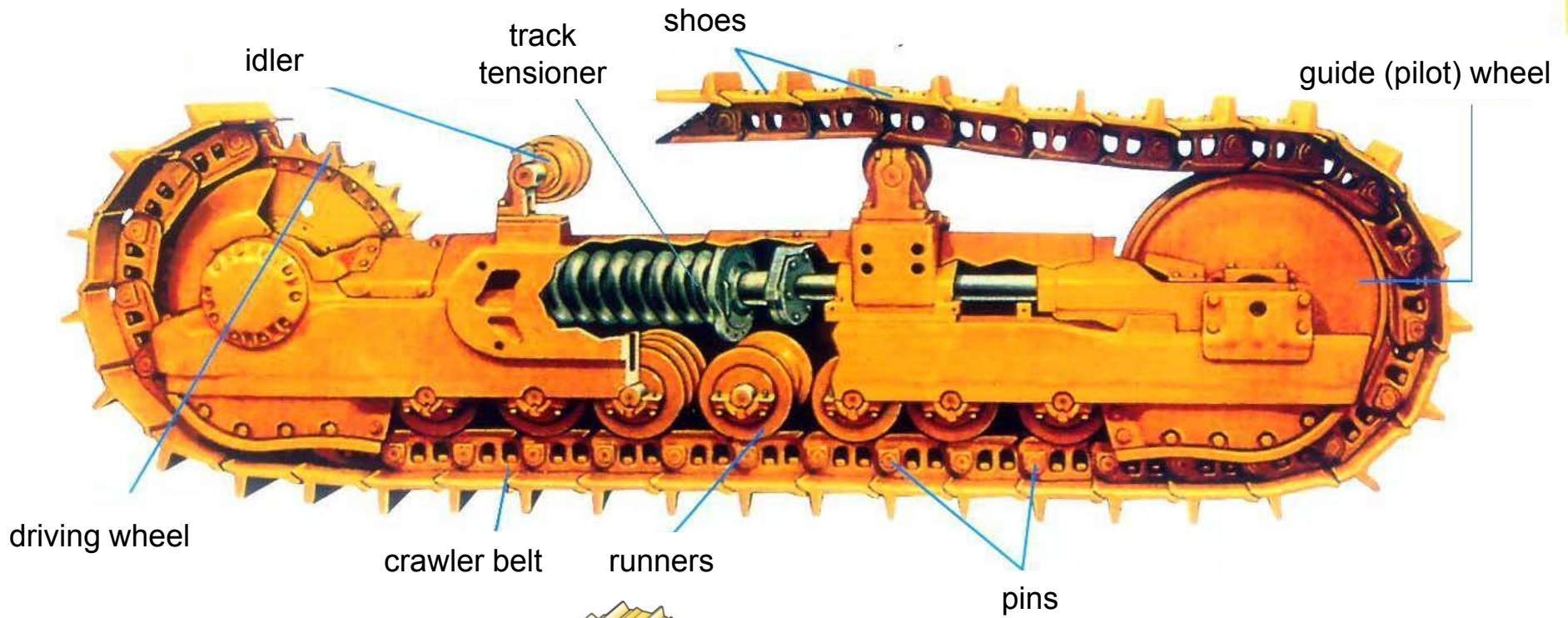

Bulldozers (dozers)

„Oval drive” (track)

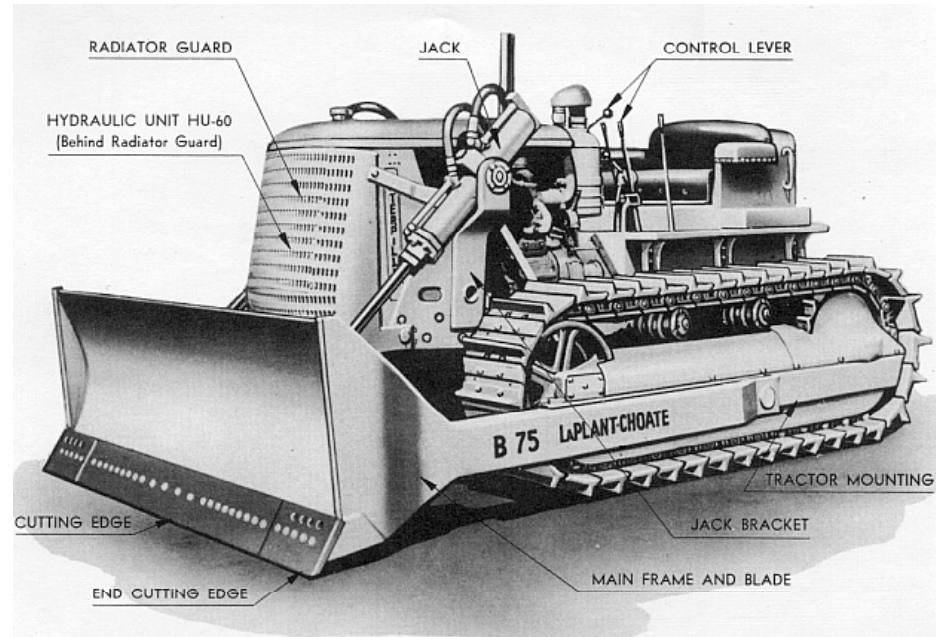

„Delta drive” (track)

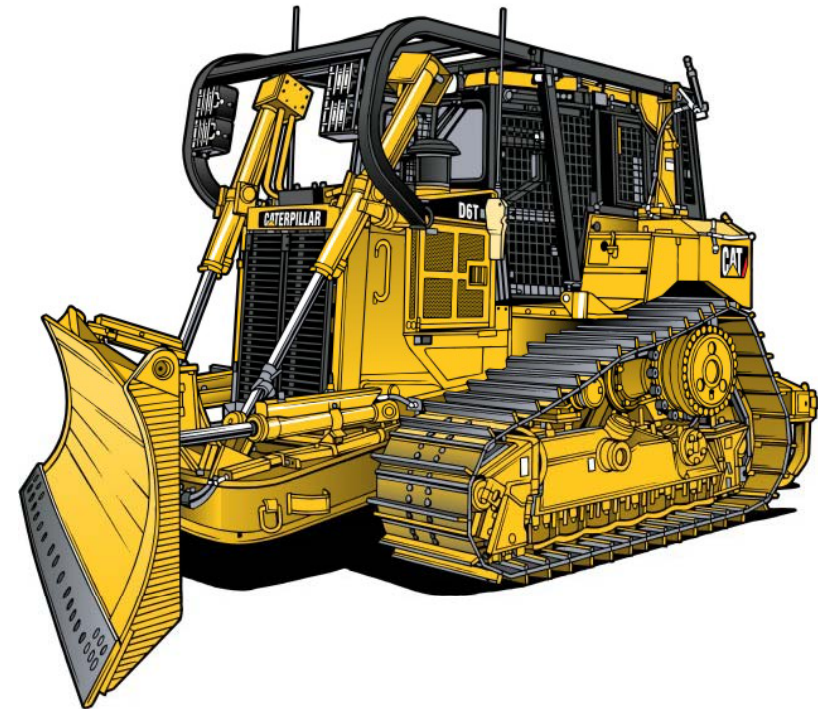

Advantages of delta drive:

- due to elevated engine and drive risk of getting dust (mud) in is less
- longer operation (life) time
- increased bulk clearance

Disadvantages of delta drive:

- higher costs of manufacturing
- more components, longer crawler belt

Bulldozers (dozers)

Up-to-date controls



Bulldozer equipped with ripper attachment



Laser control



Satellite control

Scrapers

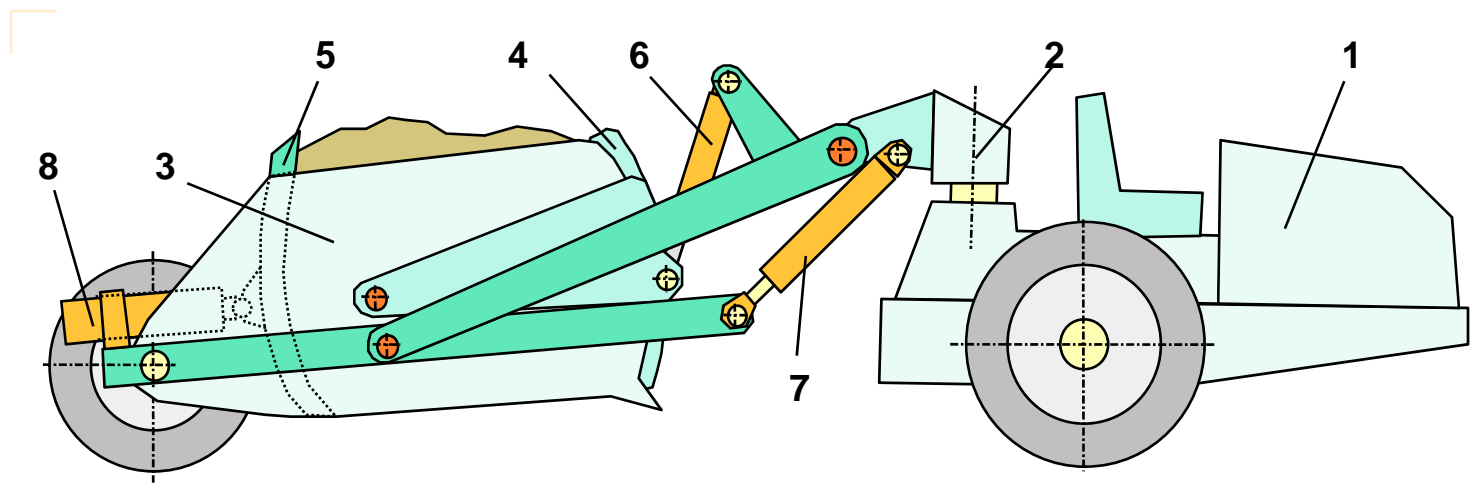

1. single-axe tractor
2. articulation

3. bowl
4. apron

5. ejector
6. apron cylinder

7. bowl cylinder
8. ejector cylinder



Hauling excavated soil



Discharging bowl, spreading soil

Scrapers

Phases of a cycle (turn)

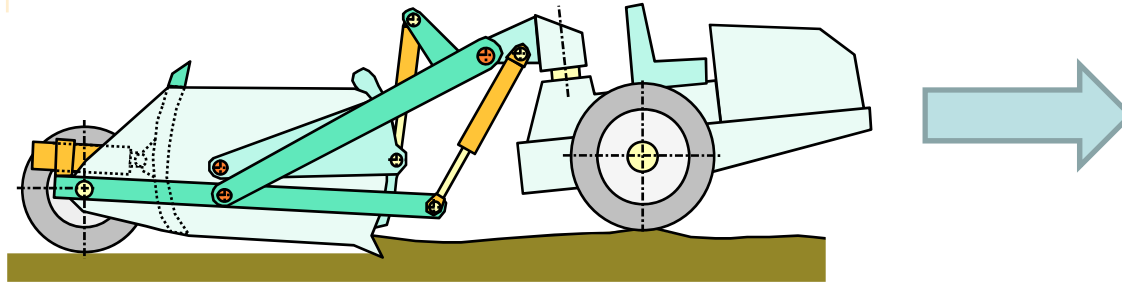

Excavating (charging): apron up (open), bowl down (penetrating into the soil)

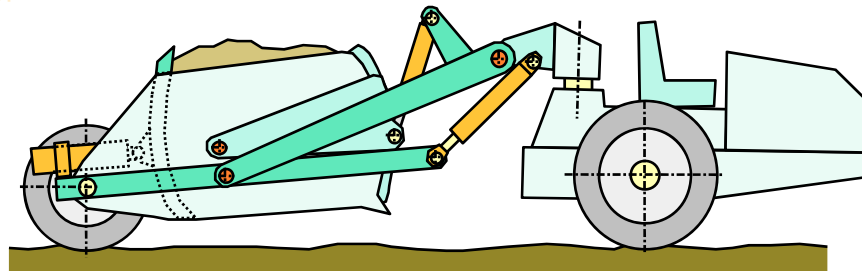

Hauling (and compacting): apron down (close), bowl up

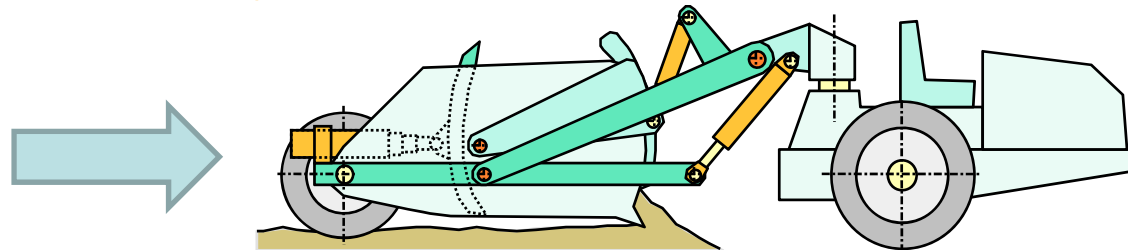

Discharging (spreading and compacting): apron up (open), bowl up, ejector forward

Scrapers

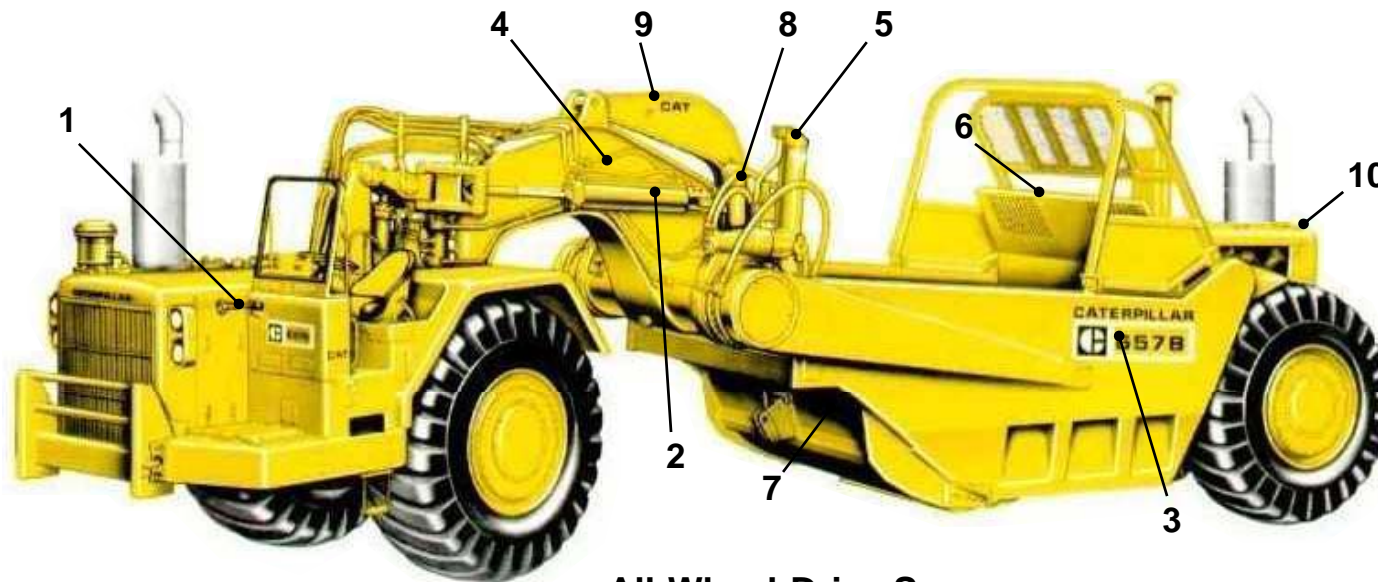

1. tractor
2. gooseneck
3. scraper bowl
4. steering cylinder
5. bowl cylinder
6. ejector
7. apron
8. apron cylinder
9. apron rods
10. rear engine
(rear wheel drive)

All-Wheel-Drive Scraper
(Charging and penetration provided by towing power of tractor)

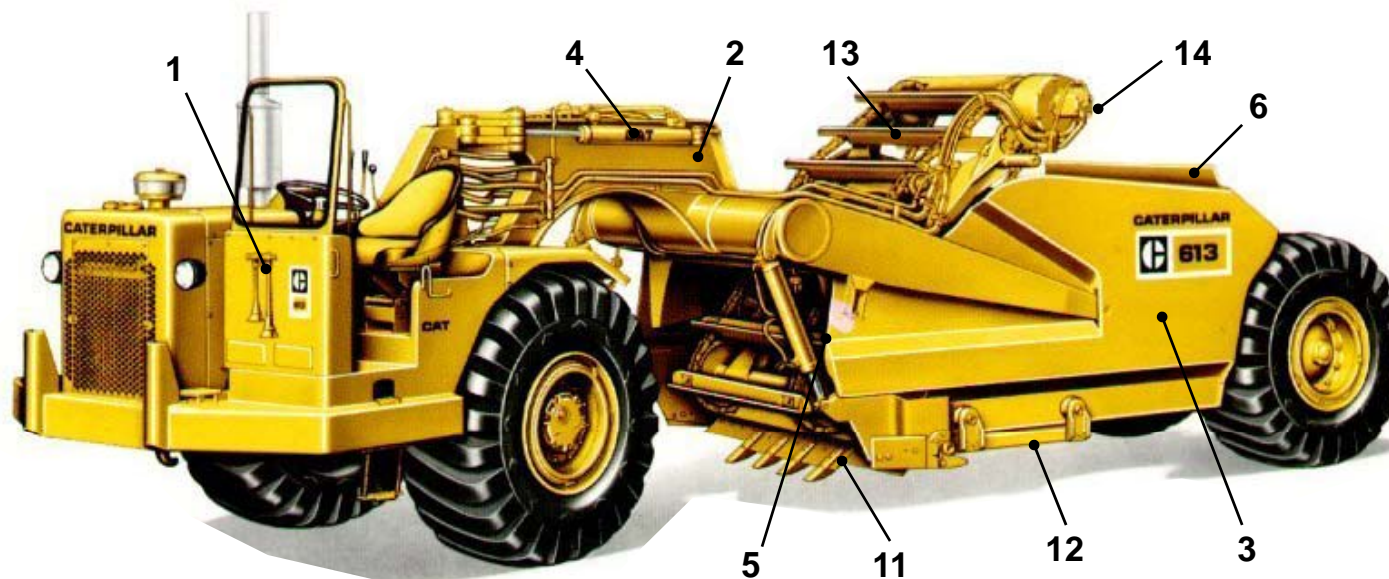

11. cutting edge
12. discharge slide
13. elevator
14. hydro-engine
(of elevator)

Elevator-scraper

Graders

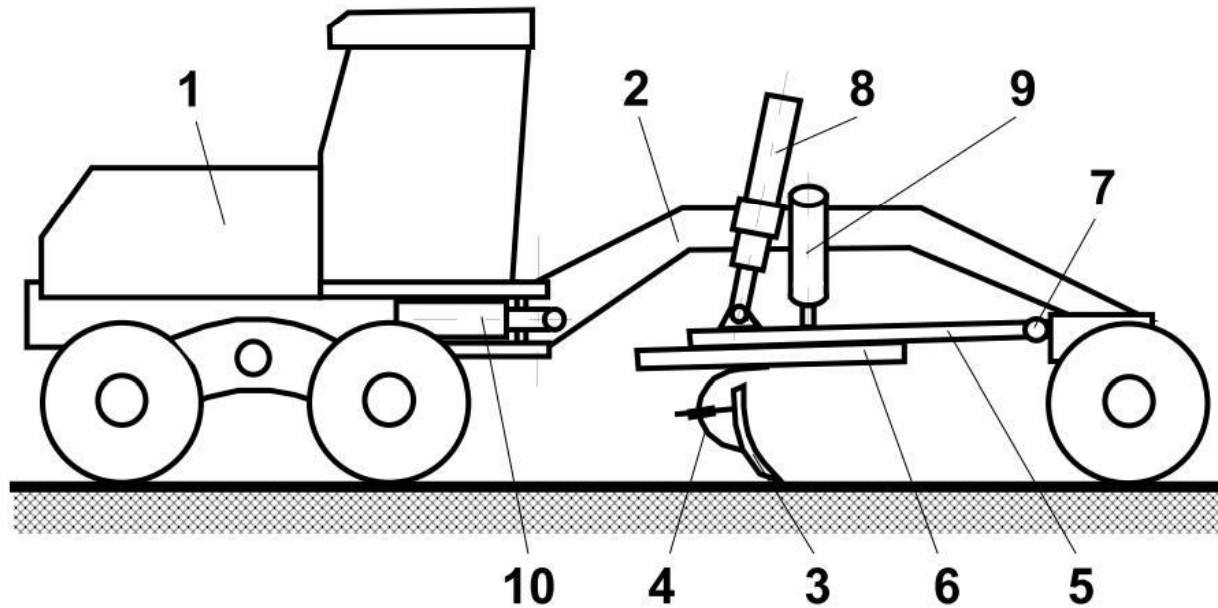

1. tractor (engine)
2. articulated carriage
3. blade
4. tilting frame
5. main frame
6. swivel ring
7. ball-joint
8. lifting cylinder (jack)
9. tilting cylinder
10. swivel cylinder

(d) cutting depth

(δ) cutting angle

(β) slope angle

(α) heading angle

(s) sliding

Adjustability of the blade

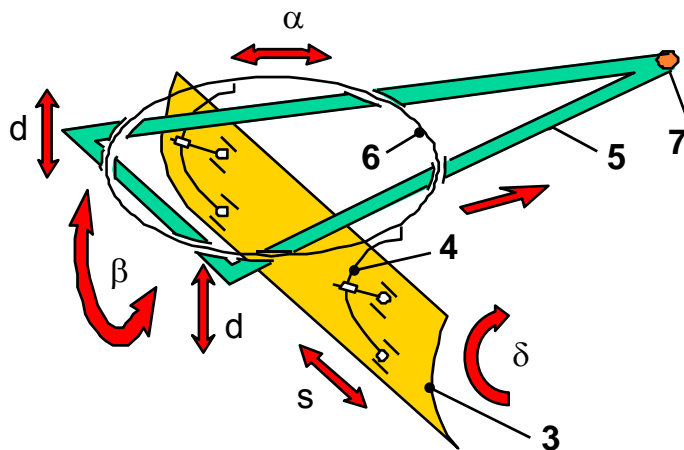

Graders

Typical application: refinery earthworks, levelling, topsoil excavation, spreading

a. grader: $H_2 < h$

**Effect of uneven surface (h)
on position of blade (H)**

b. dozer: $H_1 > h$

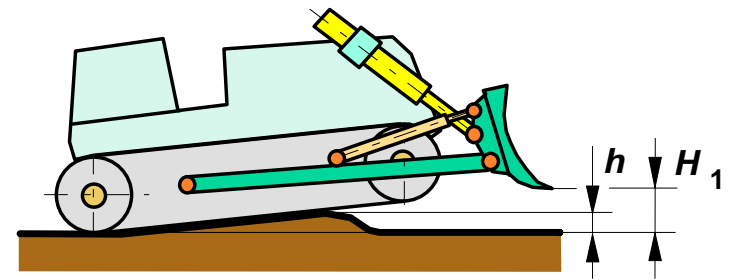
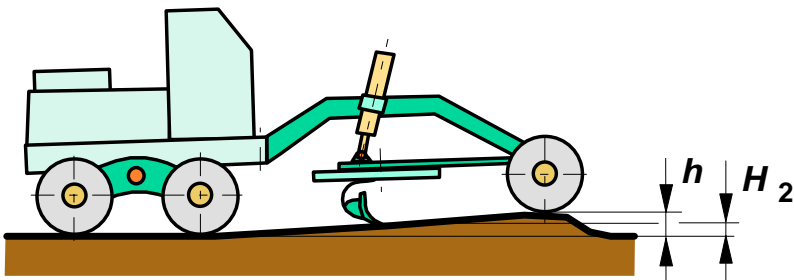

Laser controlled (C) grader equipped with ripper (A) and front blade (B) attachment

Compactors

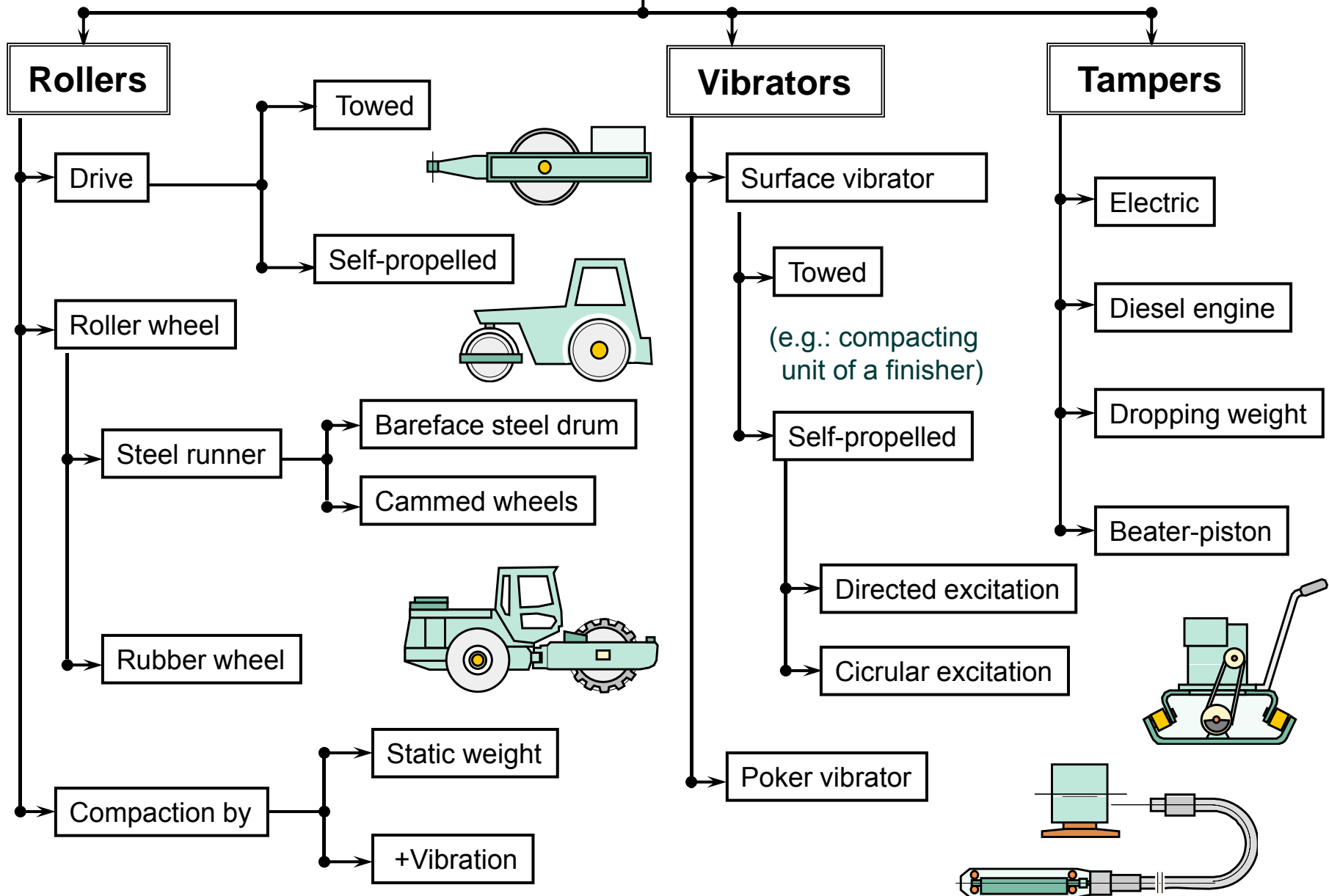

Towed rollers

Basic types:

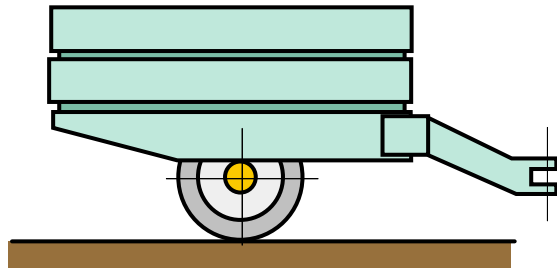

a. rubber-wheel roller

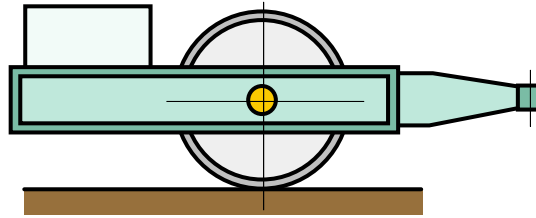

b. barefaced steel-drum

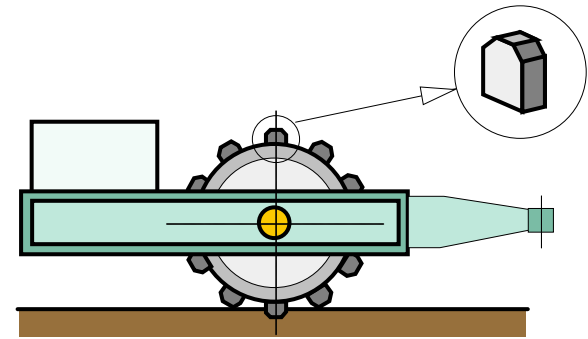

c. tamping (spiked/cammed) roller
(for clay and adherent soil)

Features:

- Main application is soil compaction
- Towed individually or in groups
- Static load transferred to the soil can be controlled by weights mounted

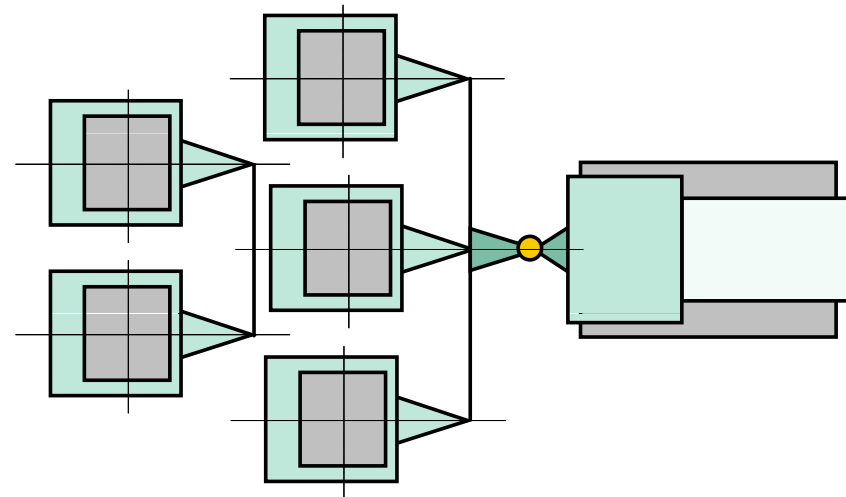

Towed group of static rollers

Self-propelled rollers



Typical configurations

a. bareface steel roller

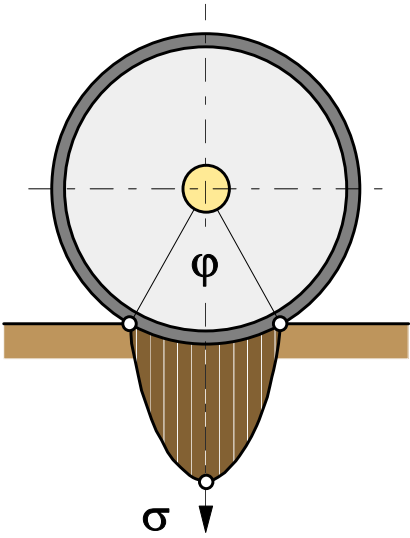

b. rubber-wheel roller

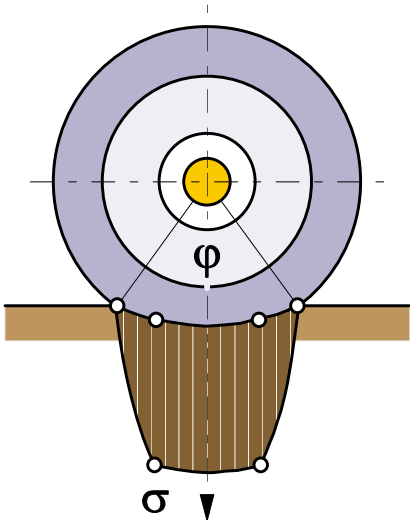

Soil compression (stress) under roller wheels

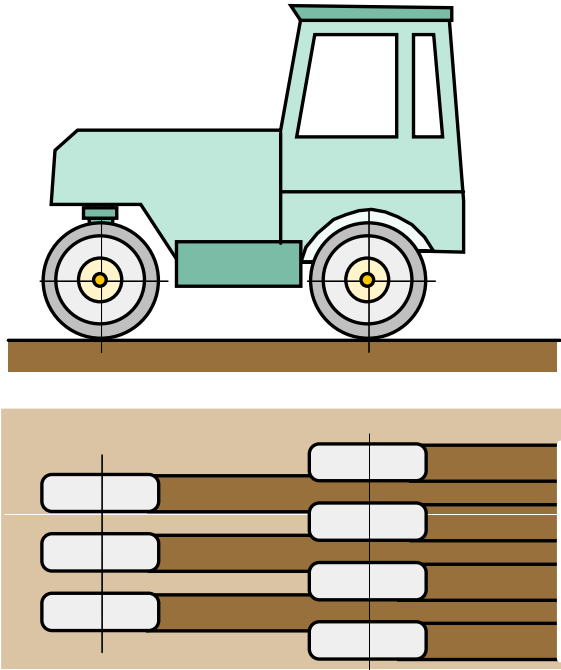

Rubber-wheel configuration

Vibratory compaction

Principle of vibratory compaction:

Grains of soil are effected by periodically alternating inertial forces. These forces make grain particles 'floating', so ordering is progressed without friction.

At vibratory compaction low amplitude high frequency excitation is used for loose soil or for deep layers. High amplitude low frequency excitation is used for cohesive soils in thin layers. Frequency of excitation should be close to characteristic frequency of the soil.

Ways of excitation:

- circular excitation: simple construction, single exciter unit, eccentric should always rotate in direction of advancing
- directed excitation: double exciter unit, generates both compressing and shearing forces in the soil simultaneously
- oscillation: the two exciter masses generate moment at the surface of the drum creating compressing and shearing forces in the soil, so grains are ordered horizontally. Vertical force is provided by the weight of the drum

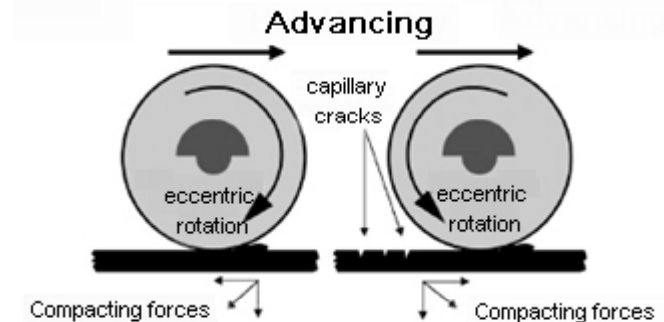

Effect of direction of rotation on the quality of compacted surface

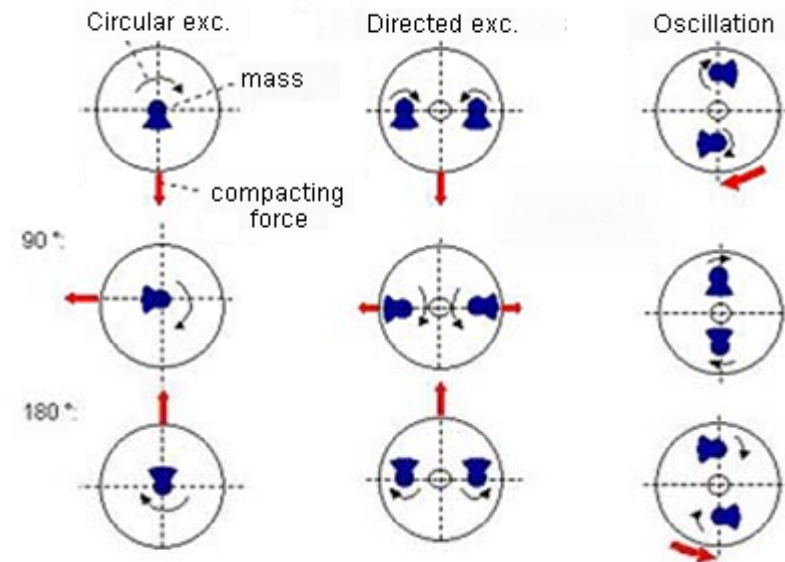

Comparison of excitation methods

Vibratory roller drives

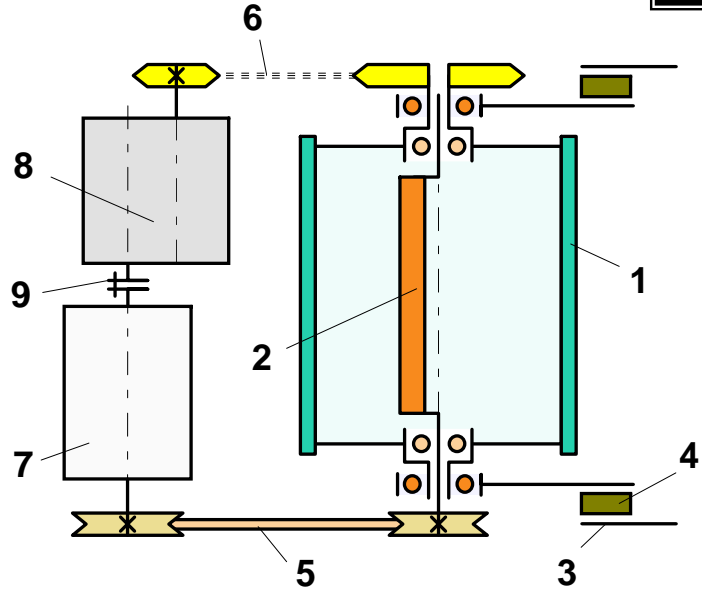

Roller Compactor: low working speed ($v = 5 \dots 20 \text{ km/h}$)
 Mechanic drive: gear-down unit (cogwheel gear, chain drive)
 Hydraulic drive: low r/min hydro-motor, high driving torque

Excentric axle: high r/min value is needed for excitation and for efficient compaction ($n = 2400 \dots 4500 \text{ r/min}$)

- 1. vibrating roller
- 2. excentric axle
- 3. carriage (frame)
- 4. rubber spring
- 5. V-belt drive
- 6. chain drive
- 7. engine
- 8. gear-down unit
- 9. clutch
- 10. exciting motor
- 11. cogwheel gear

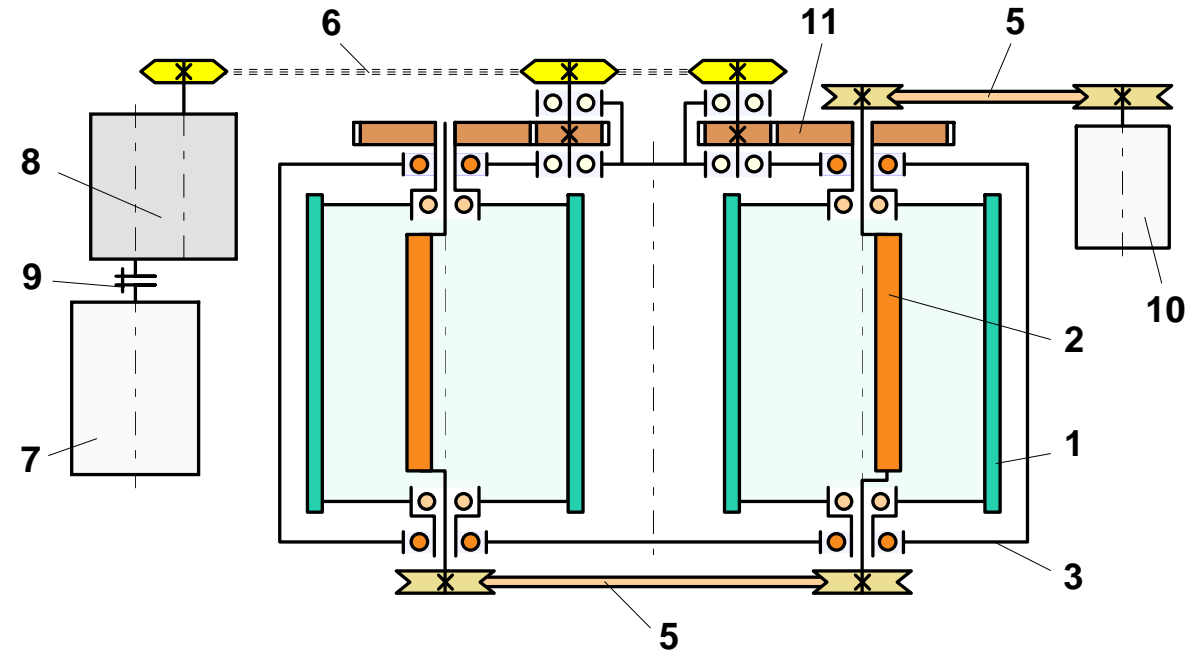

Double engine drive (both roller wheels are driven)

Vibratory roller remote control

1. vibro roller
2. exciter unit
3. controlling unit
4. monitor
5. acceleration sensor
6. radio receiver-transmitter (database + controlling-monitoring system)
7. satellite
8. adjusting direction angle

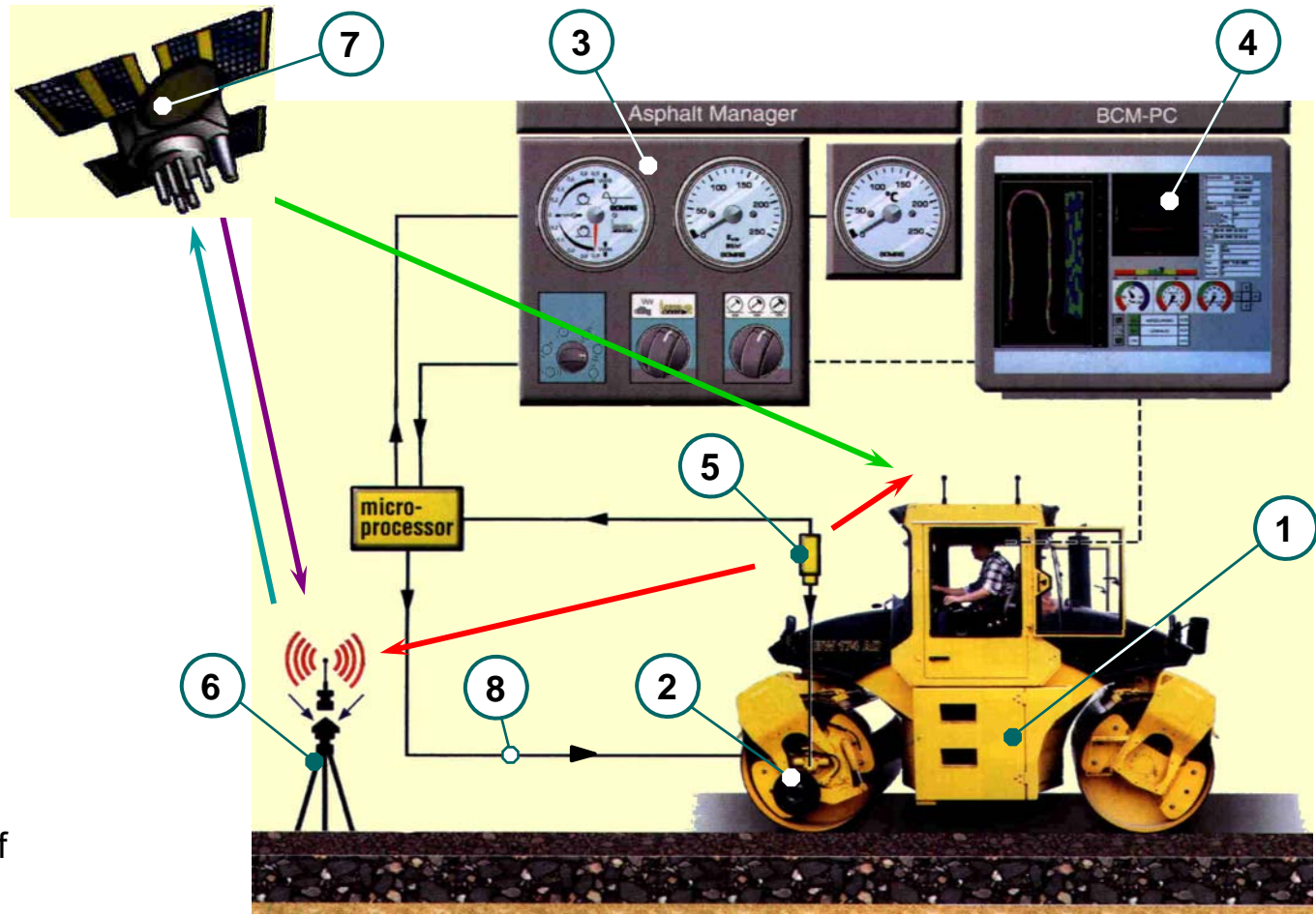

Controlling parameters:

dynamic elastic modulus of material to be compacted (via measuring acceleration)

Controlled parameters:

vertical excitation force (F_{ve})
 frequency of vibration
 working direction of the unit

$F_{ve} - MAX$

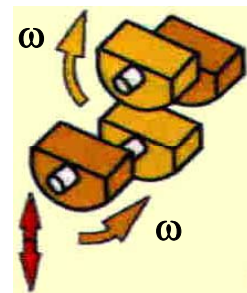

F_{ve}

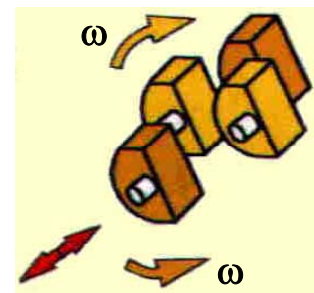

$F_{ve} - 0$

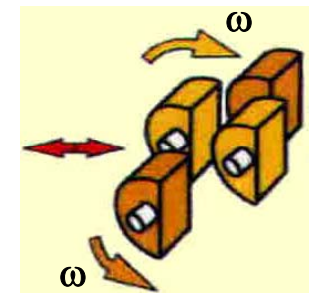

Vibro-plates

Circular excitation
(changing direction of rotation)

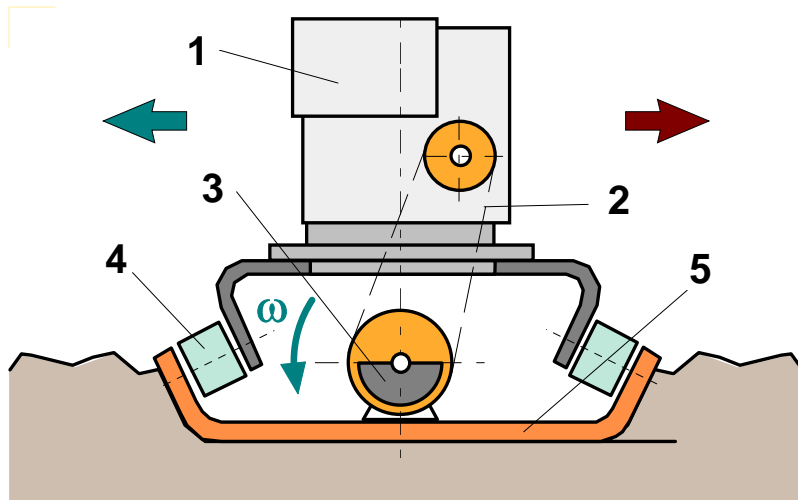

Directed excitation
(changing angle of direction)

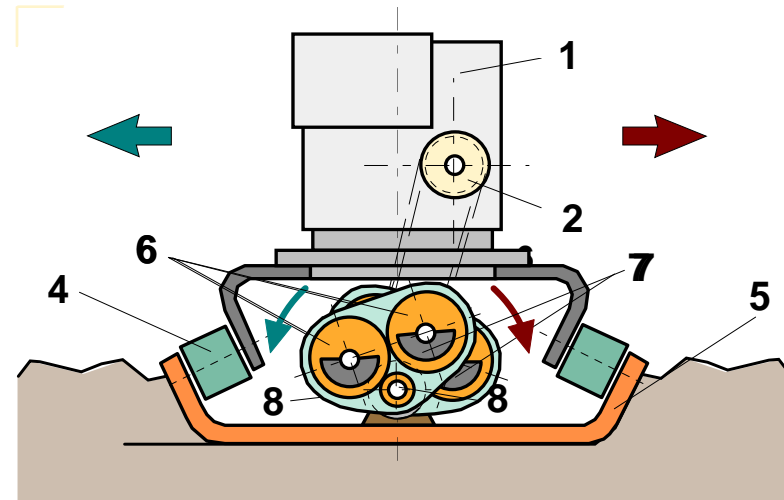

Exciter unit drive

- 1. engine
- 2. V-belt drive
- 3. exciting mass
- 4. rubber spring
- 5. compactor plate
- 6. cogwheel
- 7. exciter unit
- 8. layshaft

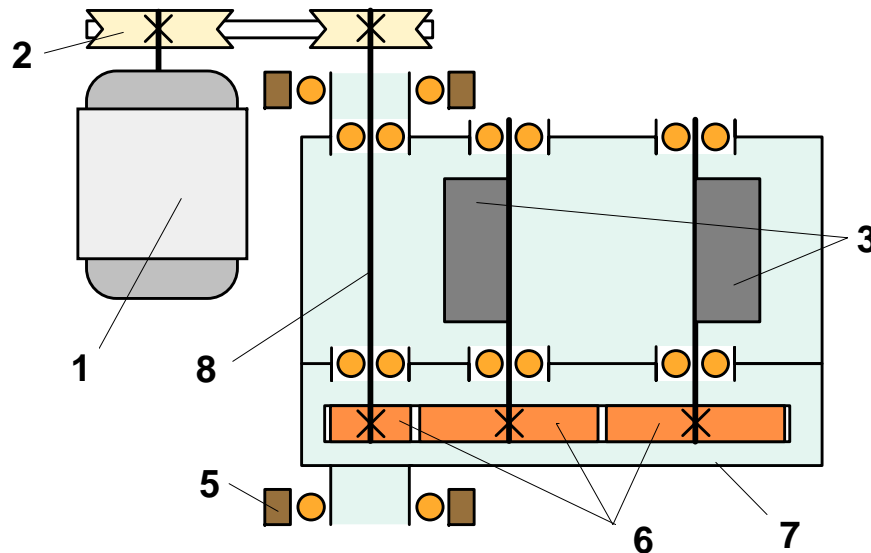

Tampers

a.

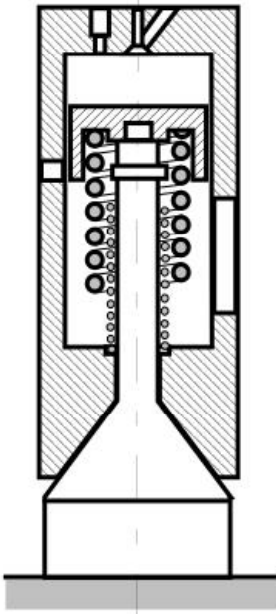

Diesel engine tamper

b.

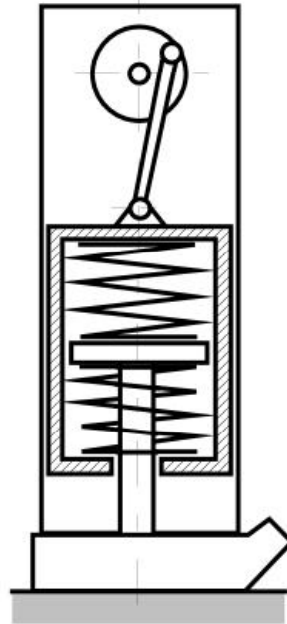

Electric tamper

c.

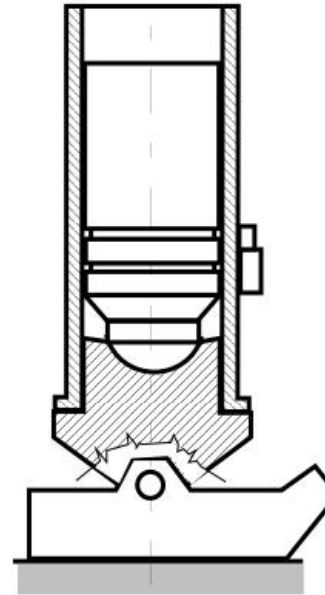

Beater-piston rammer

d.

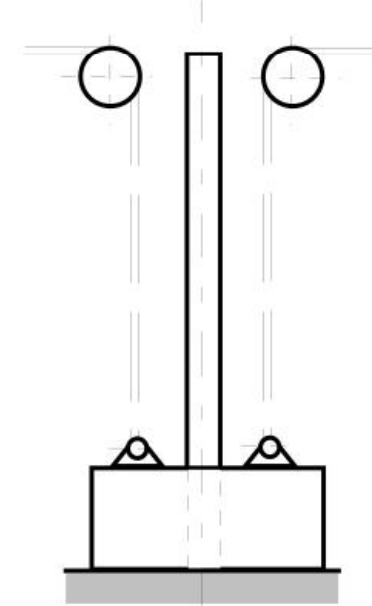

Dropping weight compactor

Tampers can be used for to compact nearly all types of soil. Thickness (depth) of layer can be compacted effectively is about 40 cm. Compaction frequency is between 2 and 15 Hz.

Applicable (effective) compaction method to be used at different types of soil

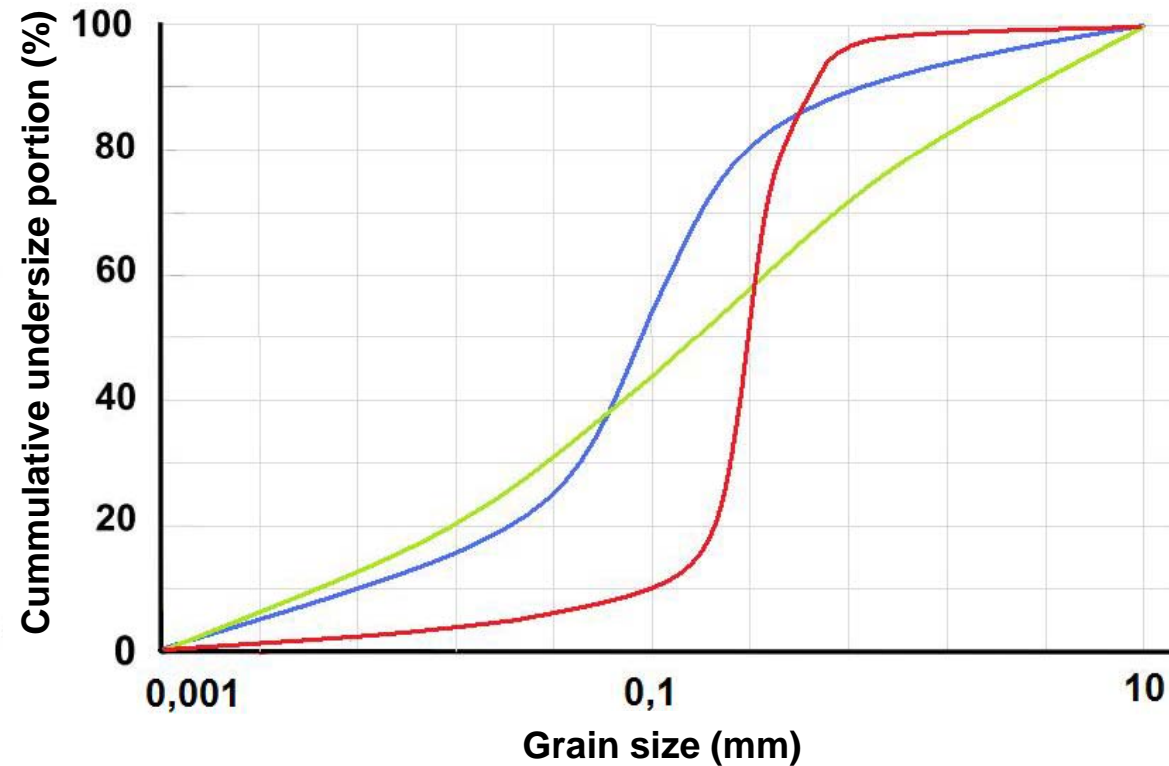

1. Single-grain soil structures → vibratory compaction
2. Well distributed grain-size → low frequency vibratory compaction
3. Air and water removal → static cammed steel drum or rubber wheel compactors
4. Sand and gravel → vibratory rollers
5. Clay and silt → cammed steel drum, sometimes rubber wheel compactors

Soil stabilization

Job: stabilizing (solidifying) loose soil structure

Methods: in-situ stabilization, pre-mixed stabilization

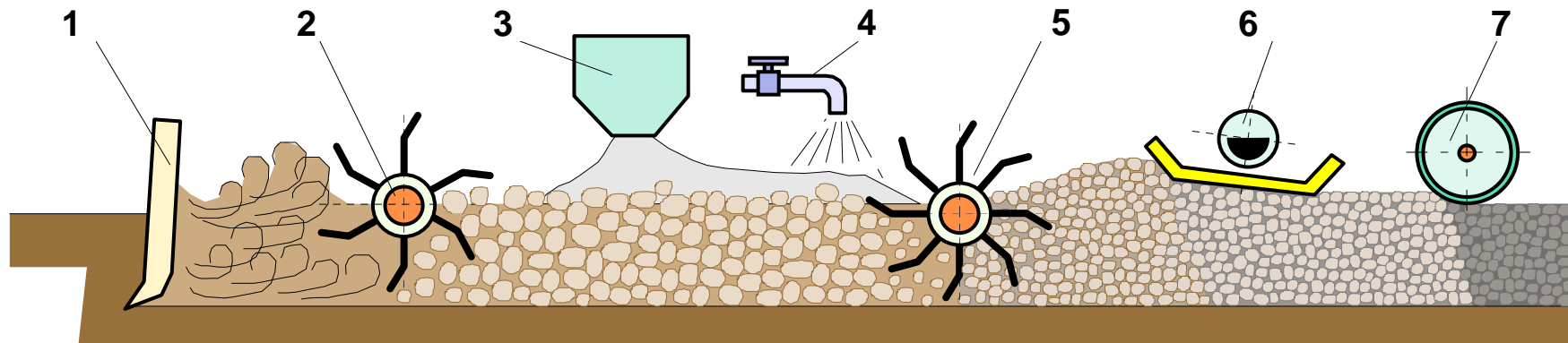

Steps (in-situ):

- ripping the soil by rippers (1)
- crushing (breaking) soil by bucket-wheels (2)
- improving soil structure by adding missing soil-fragments, or cement (3) and water (4), or lime, or asphalt, and spreading it
- mixing additives and on-site soil by bucket-wheels (5)
- compacting solidified layer by surface vibrators (6) and roller compactors (7)

Soil stabilizing and resurfacing train

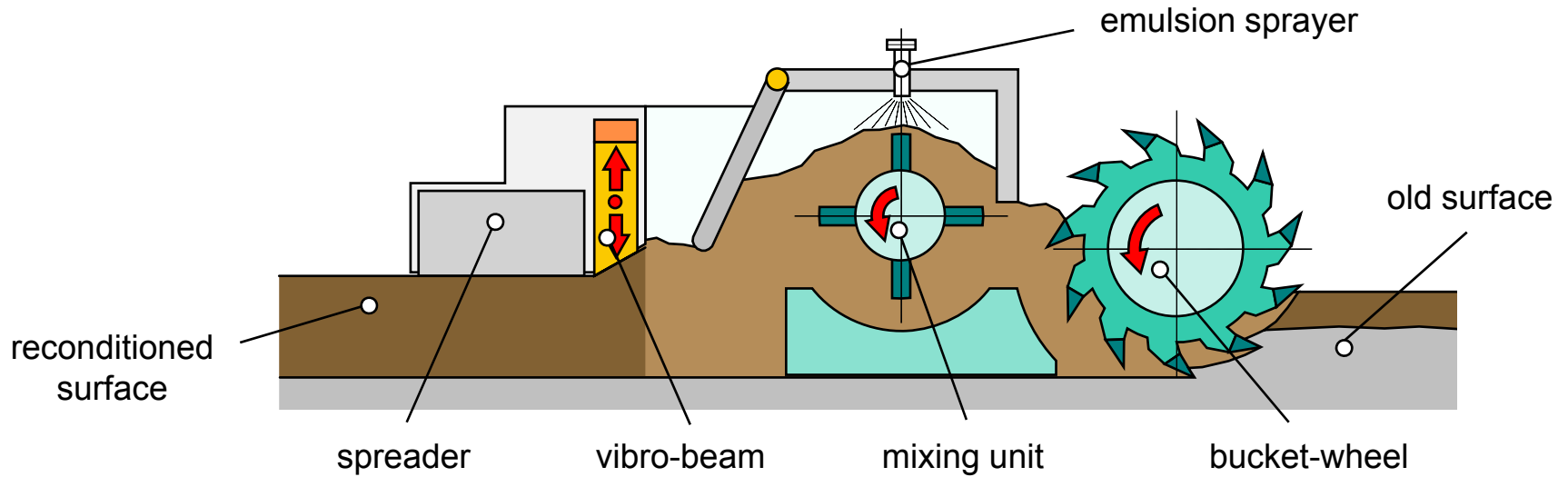

Train units:

- resurfacing unit
- water or slurry tank
- asphalt emulsion tank
- vibratory steel- and rubber-wheel rollers

